



**WEIDEMANN**

1140

1160  
1260  
1280

1160

1260

1280



**WEIDEMANN**



Weidemann GmbH  
Mühlhäuser Weg 45-49  
34519 Diemelsee-Flechtendorf  
Germany  
Tel. +49(0)5633 609-0  
Fax +49(0)5633 609-666  
info@weidemann.de  
www.weidemann.de

**The multifunctional Hoftracs®.**

Powerful machines for any job.



Your barn and yard  
operations specialists.



The Hoftrac® was invented over 40 years ago for the purpose of making heavy farmyard work easier. Now they can all do this work more efficiently, flexibly, quickly and safely. Weidemann has always been there at your side.



Individuality is tops –  
your own personal Hoftrac®.



The new basic models are the starting point for you to equip your machine to suit your own particular needs. Our reasonably priced entry-level models give you the opportunity to freely configure your machine: Choose from the many options the ones that you need for your work. In this way you can be sure that your machine will meet your needs right across the board. And the best thing about the new Hoftrac® concept is that with our 11 and 12 series models, you only pay for what you really need.

A compact design, a low centre of gravity, a narrow turning radius and powerful performance – these are the features that characterise the Hoftrac® series and shape the success of these machines in agriculture, equestrian businesses, in the commercial sector and with local authorities.

**The series for you for safe and reliable working in very confined spaces:**

- Low clearance heights and widths negotiated with ease.
- Buckle-resistant lifting arms for precise operation and remarkable lifting heights.
- High thrust.
- Large selection of attachments.
- The right tyres for every job.
- Simple tool change.



**Your Hoftrac® is entirely your machine:**  
 Individually designed. Built to meet your needs.  
 Always on form.

**Exactly what you want from your machine.** Combine the engine, driver's cab and tyres to get the machine you want. Plenty of intelligent accessories also transform it into your choice of attachment mount. After all, a Weidemann can do more.



**Your new workplace:** A low climb, an ergonomically designed driver's cab and a comfortable seat that you can adjust precisely to suit your weight and body size. Just own quality.

**Stable when stationary, safe driving.** The low centre of gravity gives your Weidemann secure contact with the ground when on uneven terrain. Down to earth and safe.

**Change the attachment without climbing out.** The optional hydraulic lock makes work easier for you, and your Weidemann particularly versatile and flexible. It can be reconfigured for new jobs within a matter of seconds.

**A class above.** Enormous lifting heights despite its compact and low design. The angled lifting arm has an extremely high load-bearing capacity and is resistant to buckling. Its shape supports the precision of your work. Clear visibility of the attachment and the working area.

**Power kinematics for short work cycles.** A large hydraulic cylinder generates enormous biting forces. This means that the material being transported is picked up quickly. This force also speeds up unloading. This saves you time.



1140

1160

1240 CX35 LP

1260

1280

1140  
 1160  
 1240  
 1260  
 1280



## Practice as a designer: A careful look and stable construction.

Twice the strength instead of half measures. Maximum balance and stability can be achieved with only two lifting cylinders. This delivers safety and is gentle on the components.



**State-of-the-art maximum safety.** The overhead guard and the new restraint system for the driver comply with the current European Machinery Directive (2006/42/EC).



1



2



3

### Weidemann factors:

- Maximum manoeuvrability thanks to a maximum inclination of up to 55 °.
- ROPS / FOPS-compliant overhead guard with restraint system as standard, or optionally the folding Easy Protection System (eps) overhead guard.
- Control by multi-function control stalk and joystick.
- Good component accessibility thanks to tilting driver's cab and engine bonnet.



### 1 Boost productivity.

The engine bonnet and seat are tilted together. What you can save in work steps every day boosts your productivity.

### 2 Intelligent Weidemann articulated oscillating joint.

All four wheels are in constant contact with the ground and the machine moves with maximum traction. This makes the machine uniquely manoeuvrable.

### 3 Robust and sensitive control.

With the joystick, the entire machine is in your hands. Robust and sensitive control for all movements and for the complete kinematics.





## Simply impressive: Brand name quality in every detail.

### An idea that has always been true to itself.

Your Weidemann is a specialist. It is made in Germany, in one of the most modern manufacturing plants in Europe. Today, more than ever, it is what it always was – a multitalent that has grown up in an agricultural background. Practical, robust and durable. A helper you can depend on like on a good neighbour. That's its product personality. And its quality.

### Weidemann factors:

- Simple and safe handling thanks to multi-function control stalks.
- Low front carriage for a clear view of the attachment.
- Efficient and economical.
- Compact design.



**Low position (LP) for high performance.** The driver's low seat position allows a lower overall height. Other advantages: The machine's centre of gravity is close to the ground, comfortable climb, better contact with the working environment and a feeling of safety when driving.

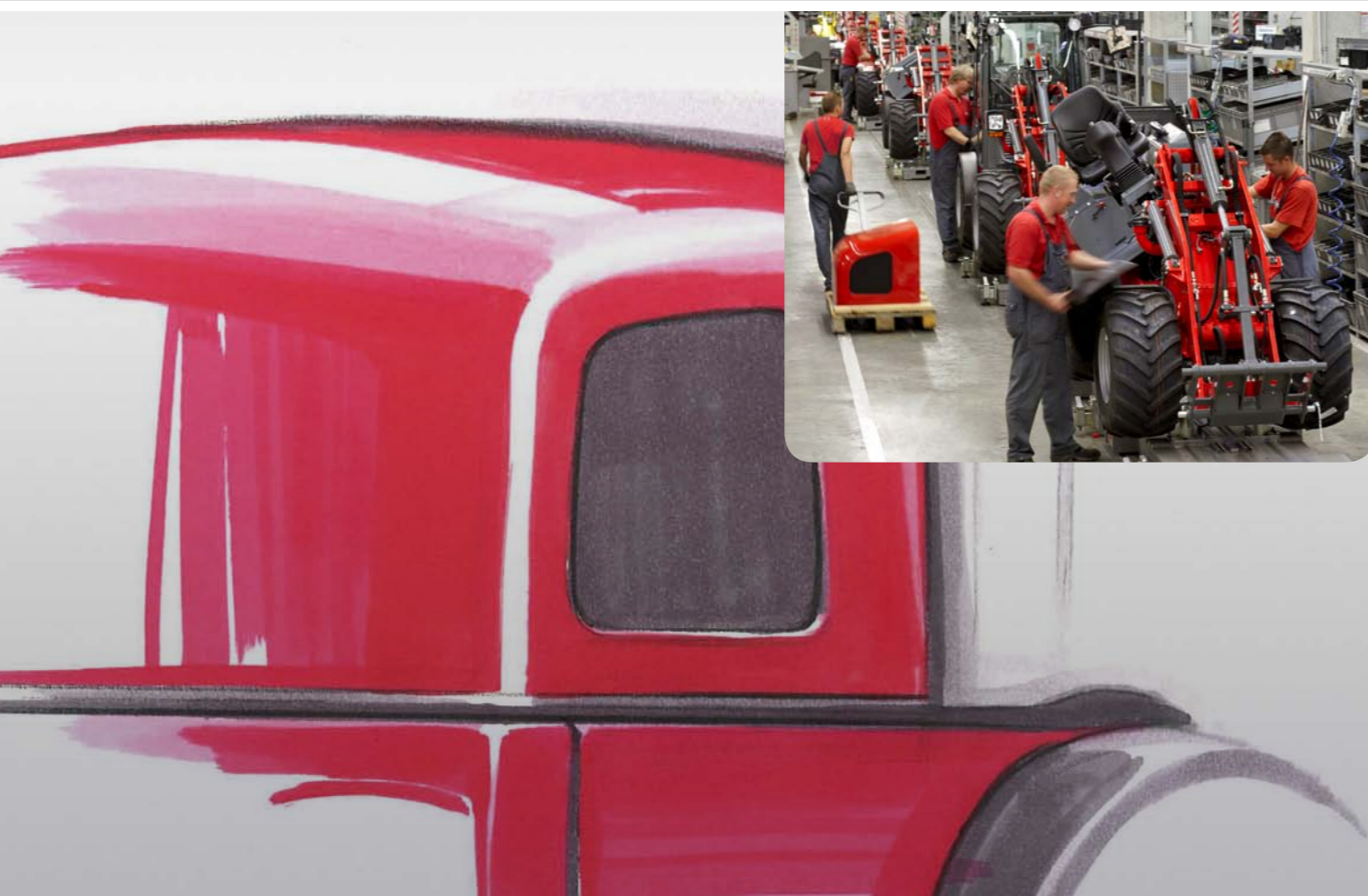

**Safe transport.** The lifting force, the articulated oscillating joint and the precision steering combine optimally. Maximum traction and directional stability are always guaranteed even on uneven terrain.

**Angled lifting arm.** Technical refinements and skilled engineering where they serve stability, suitability for everyday use and the machine's long-term quality. That's Weidemann quality that impresses every day.



The word is out:  
The 12 series is tops!



**Optimum comfort.** Simply drive up to the attachment, pick it up hydraulically from your seat and lock / unlock it while maintaining constant visual contact. This makes work so much easier.

**The Hoftracs® speak for themselves.**  
And enthusiastic customers often speak for them.

A brand name like Weidemann that's steeped in tradition lives from its good reputation. That's why every machine must at the same time also represent practical evidence of performance. But we're also only really satisfied when Weidemann customers are impressed by everything – the machine, the service, the economy ... and us.

Because that's not just the best advert for us, it's also our future. And once again, that's the best guarantee for all partners who place their trust in us.

**MAINTENANCE.  
SERVICE.  
VALUE RETENTION.**

*"Buyers who opt for a Weidemann machine, opt for high dependability."*

R. Nagel, Germany  
Boarding stables  
and crop cultivation



The Easy Protection System (eps) folding overhead guard can be prepared for low clearances with just a few manual actions.



## Trained in practice. Superior in competition.

Only that which proves itself in practice is also of value in terms of its technology.

Everyday farming is often hard and unpredictable. That's why every machine must also have reserves in order to be prepared for that well-known "exceptional situation". That applies to both performance and unusual jobs, as well as to all aspects of safety at work. Your Hoftrac® is always able to do more than what it's called upon to perform. That's what makes it powerful and unique. That's what make it a Weidemann.



**Tiltable driver's cab.** Uncomplicated access to the engine, hydraulic system and electricals. Maintenance and inspection made easy.



**Increasing the tipping load.** The optional rear and ballast weights allow you to significantly increase the machine's tipping load and stability.



**Greater stability.** The machine's stability can be increased by the optional water filling for the front and rear tyres – for 100% use of the machine's potential.



**The multi-function control stalk / joystick puts the entire machine in your hands.** Robust and sensitive control for all lifting and lowering movements and for angling the attachment in and out with just one lever. As an option, the 12 series joystick can be supplemented with additional functions.



**Battery cut-off switch for added safety.** As protection for the vehicle's power supply, as a safeguard against theft and not least as a guarantee for insurance protection.



**Great lifting force as standard.** The two optimally dimensioned lifting cylinders give the machine above-average power.



**An ergonomically optimised workplace.** A cockpit that you know your way around immediately and where you'll feel comfortable. A spring-mounted comfortable seat with safety belt, good all-round visibility and a clear view of the attachments for fatigue-free working.



The Hoftracs® in daily use:  
Performance couldn't be any  
more convincing.



The practical side is what matters most.  
Machines which prove their capabilities  
day in, day out: power, versatility and the  
capacity to get straight down to the job.  
With maximum efficiency and the best result  
in the shortest time.





# No two Hoftracs® are identical.

## Why not just put together your own vehicle ...

It's not the sheer number of models that matters when finding the best solution to a problem, it's the individual machine configuration for the work in question.

Our four basic models, the 1140, 1160, 1260 and 1280, have replaced the existing variety of many different types and offer you the possibility of reasonably-priced entry-level models. In addition, there is still also a LP Hoftrac with a particularly low overall height.

Simply choose from our range of options and configure your Hoftrac® to suit the work you do and your operational requirements.

And the best thing about the new Hoftrac® concept is that you pay only for the configuration of your individual machine, in other words only for what you really need.

On the following pages you will find the standard features and options, along with technical data for our 11 and 12 series.

1140



1160



1240 CX35 LP



1260



1280



### STANDARD EQUIPMENT AND OPTIONS

|   | 1140 | 1160 | 1240<br>CX LP | 1260 | 1280 |
|---|------|------|---------------|------|------|
| <b>DRIVE</b>  |      |      |               |      |      |
| Hydraulic drive via oil motor   | ●    | -    | -             | -    | -    |
| Hydrostatic drive via oil motor   | ○    | ●    | ●             | ●    | -    |
| Hydrostatic drive via drive shaft   | -    | ○    | -             | ○    | ●    |
| Pto gear and drive shaft  | -    | ○    | -             | ○    | ●    |
| Weidemann axle K75  | ●    | -    | -             | -    | -    |
| Weidemann axle K80  | -    | ●    | ●             | ●    | -    |
| Weidemann axle K90  | ○    | -    | ○             | ○    | -    |
| Weidemann axle T80  | -    | ○    | -             | ○    | -    |
| Weidemann axle T94  | -    | ○    | -             | ○    | ●    |
| Differential lock 100 %, can be switched between electrical and hydraulic at the front and rear axles | -    | ○    | -             | ○    | ○    |
| <b>STANDARD TYRES (see Page S.25/27 for more)</b>   |      |      |               |      |      |
| Tyres 7.00 - 12 AS ET40 including turning rims  | ●    | ○    | ○             | ○    | -    |
| Tyres 27 x 8.50 - 15 EM ET30 including turning rims   | ○    | ○    | ●             | ●    | -    |
| Tyres 10.0/75 - 15 AS ET10  | -    | ●    | -             | ○    | -    |
| Tyres 10.0/75 - 15 AS ET80 including turning rims   | -    | -    | -             | -    | ●    |
| <b>HYDRAULICS</b>   |      |      |               |      |      |
| Multi-function control stalk  | ●    | -    | -             | -    | -    |
| Joystick  | ○    | ●    | ●             | ●    | ●    |
| Front hydro connection DN10   | ●    | ●    | ●             | ●    | ●    |
| Greasable articulated steering  | ●    | ●    | ●             | ●    | ●    |
| <b>DRIVER'S CAB</b>   |      |      |               |      |      |
| Overhead guard with restraint system ROPS / FOPS-compliant  | ●    | ●    | ●             | ●    | ●    |
| Easy Protection System (eps) ROPS and FOPS-compliant  | ○    | ○    | -             | ○    | ○    |
| Cabin with heating, ventilation and windscreen wipers ROPS / FOPS-compliant                           | -    | -    | -             | -    | ○    |
| 3 work lamps on the driver's cab  | ●    | -    | ●             | -    | -    |
| 4 work lamps on the driver's cab  | -    | ●    | -             | ●    | ●    |
| Driver's cab can be tilted laterally  | -    | ●    | -             | ●    | ●    |
| Engine bonnet incl. seat can be tilted sideways   | ●    | -    | -             | -    | -    |
| Comfortable seat with safety belt, completely spring-mounted  | ●    | ●    | ●             | ●    | ●    |
| Fuel gauge  | ●    | ●    | ●             | ●    | ●    |
| Engine-hour indicator   | ●    | ●    | ●             | ●    | ●    |
| Lighting system in acc. with the Road Traffic Licensing Regulations                                   | ○    | ○    | ○             | ○    | ○    |
| Approval of Technical Inspection for road worthiness  | ○    | ○    | ○             | ○    | ○    |
| <b>OTHER</b>  |      |      |               |      |      |
| Battery cut-off switch  | ●    | ●    | ●             | ●    | ●    |
| Ballast weight  | ○    | -    | -             | -    | -    |
| Cast rear weight incl. self-recovery coupling   | -    | ○    | -             | ○    | ○    |
| Ballast weight (base plate)   | -    | ○    | ○             | ○    | ○    |
| Front mudguard  | ●    | ●    | ●             | ●    | ●    |
| Rear mudguard   | -    | ●    | -             | ●    | ●    |
| Mechanical rapid-change system for attachments  | ●    | ●    | -             | ●    | ●    |
| Hydraulic rapid-change system for attachments   | ○    | ○    | ●             | ○    | ○    |
| High lifting height   | -    | ○    | ○             | ○    | ○    |

- Standard
- Option
- Not possible

Specifications are subject to change without notice. We cannot be held liable for the accuracy of information supplied in this document. Liability will arise solely on the basis of the contractual agreement.



|   | 1140<br>Standard | 1140<br>Configuration<br>example | 1160<br>Standard | 1160<br>Configuration<br>example 1 | 1160<br>Configuration<br>example 2 | 1240<br>CX35 LP | 1260<br>Standard    | 1260<br>Configuration<br>example 1 | 1260<br>Configuration<br>example 2 | 1280<br>Standard | 1280<br>Configuration<br>example |
|---|------------------|----------------------------------|------------------|------------------------------------|------------------------------------|-----------------|---------------------|------------------------------------|------------------------------------|------------------|----------------------------------|
| <b>TECHNICAL DATA</b>                                     |                  |                                  |                  |                                    |                                    |                 |                     |                                    |                                    |                  |                                  |
| <b>ENGINE DATA</b>  |                  |                                  |                  |                                    |                                    |                 |                     |                                    |                                    |                  |                                  |
| Manufacturer  | Perkins          | Perkins                          | Perkins          | Perkins                            | Perkins                            | Perkins         | Perkins             | Perkins                            | Perkins                            | Perkins          | Perkins                          |
| Engine type   | 403 D-11         | 403 D-11                         | 403 D-11         | 403 D-15                           | 403 D-15                           | 403 D-15        | 404 D-15            | 404 D-15                           | 404 D-15                           | 404 D-15         | 404 D-15                         |
| Cylinder  | 3                | 3                                | 3                | 3                                  | 3                                  | 3               | 4                   | 4                                  | 4                                  | 4                | 4                                |
| Max. power kW/HP  | 18.5/25          | 18.5/25                          | 18.5/25          | 23.4/32                            | 23.4/32                            | 24.4/33         | 24.6/33             | 24.6/33                            | 24.6/33                            | 24.6/33          | 24.6/33                          |
| At rpm  | 2,800            | 2,800                            | 2,800            | 2,600                              | 2,600                              | 2,800           | 2,800               | 2,800                              | 2,800                              | 2,800            | 2,800                            |
| Capacity cm <sup>3</sup>                                  | 1,131            | 1,131                            | 1,131            | 1,496                              | 1,496                              | 1,496           | 1,508               | 1,508                              | 1,508                              | 1,508            | 1,508                            |
| Cooling   | Water            | Water                            | Water            | Water                              | Water                              | Water           | Water               | Water                              | Water                              | Water            | Water                            |
| <b>ELECTRICAL SYSTEM</b>                                  |                  |                                  |                  |                                    |                                    |                 |                     |                                    |                                    |                  |                                  |
| Operating voltage V                                       | 12               | 12                               | 12               | 12                                 | 12                                 | 12              | 12                  | 12                                 | 12                                 | 12               | 12                               |
| Battery Ah  | 77               | 77                               | 77               | 77                                 | 77                                 | 77              | 77                  | 77                                 | 77                                 | 77               | 77                               |
| Generator A   | 40               | 40                               | 40               | 65                                 | 65                                 | 65              | 65                  | 65                                 | 65                                 | 65               | 65                               |
| <b>WEIGHTS</b>  |                  |                                  |                  |                                    |                                    |                 |                     |                                    |                                    |                  |                                  |
| Operating weight (standard) kg                            | 1,630            | 1,630                            | 1,910            | 2,060                              | 2,150                              | 1,840           | 2,080               | 2,170                              | 2,290                              | 2,380            | 2,550                            |
| Lifting force max. daN                                    | 1,981            | 1,981                            | 2,170            | 2,170                              | 2,170                              | 2,500           | 2,473               | 2,473                              | 2,473                              | 2,473            | 2,473                            |
| <b>Tipping loads, bucket (according to ISO 8313)</b>      |                  |                                  |                  |                                    |                                    |                 |                     |                                    |                                    |                  |                                  |
| Lift frame horizontal / machine straight kg               | 664              | 688 / 846*                       | 905              | 994                                | 1,144 / 1,285**                    | 1,118           | 1,018               | 1,057 / 1,357***                   | 1,118 / 1,389***                   | 1,174 / 1,445*** | 1,278 / 1,549***                 |
| Lift frame horizontal / machine articulated kg            | 490              | 509 / 621*                       | 660              | 727                                | 882 / 994**                        | 926             | 766                 | 827 / 1,032***                     | 861 / 1,078***                     | 958 / 1,175***   | 1,044 / 1,261***                 |
| <b>Tipping loads, pallet fork (according to ISO 8313)</b> |                  |                                  |                  |                                    |                                    |                 |                     |                                    |                                    |                  |                                  |
| Lift frame horizontal / machine straight kg               | 532              | 556 / 679*                       | 718              | 792                                | 934 / 1,048**                      | 850             | 831                 | 871 / 1,122***                     | 919 / 1,136***                     | 965 / 1,182***   | 1,080 / 1,297***                 |
| Lift frame horizontal / machine articulated kg            | 391              | 407 / 497*                       | 521              | 576                                | 721 / 808**                        | 704             | 622                 | 675 / 857***                       | 714 / 892***                       | 786 / 964***     | 874 / 1,052***                   |
| <b>VEHICLE DATA</b>                                       |                  |                                  |                  |                                    |                                    |                 |                     |                                    |                                    |                  |                                  |
| Driver's cab (optional)                                   | FSD (eps)        | FSD (eps)                        | FSD (eps)        | FSD (eps)                          | FSD (eps)                          | FSD (eps)       | FSD (eps)           | FSD (eps)                          | FSD (eps)                          | FSD (eps, Cabin) | Cabin                            |
| Axle (optional)   | K75 (K90)        | K75 (K90)                        | K80 (T80, T94)   | T80                                | T94                                | K80             | K80 (K90, T80, T94) | T80                                | T94                                | T94              | T94                              |
| Driving speed (optional) km/h                             | 0-12             | 0-13                             | 0-13 (20, 30)    | 0-20                               | 0-20 (30)                          | 0-13            | 0-13 (20, 30)       | 0-20                               | 0-20 (30)                          | 0-20 (30)        | 0-20 (30)                        |
| Speed stages (optional)                                   | 1                | 1                                | 1 (2)            | 2                                  | 2                                  | 1               | 1 (2)               | 2                                  | 2                                  | 2                | 2                                |
| Capacity of fuel tank l                                   | 21               | 21                               | 20               | 20                                 | 20                                 | 21              | 40                  | 40                                 | 40                                 | 43               | 43                               |
| Hydraulic oil l   | 18               | 18                               | 20               | 20                                 | 20                                 | 12              | 27                  | 27                                 | 27                                 | 27               | 27                               |
| <b>HYDRAULIC SYSTEM</b>                                   |                  |                                  |                  |                                    |                                    |                 |                     |                                    |                                    |                  |                                  |
| <b>Hydraulic driving</b>                                  |                  |                                  |                  |                                    |                                    |                 |                     |                                    |                                    |                  |                                  |
| Working pressure bar                                      | 215              | 305                              | 305              | 305                                | 450                                | 305             | 305                 | 330                                | 330                                | 330              | 450                              |
| <b>Hydraulic operation</b>                                |                  |                                  |                  |                                    |                                    |                 |                     |                                    |                                    |                  |                                  |
| Output l/min  | 30.8             | 30.8                             | 30.8             | 30.8                               | 36.4                               | 44.8            | 44.8                | 44.8                               | 44.8                               | 44.8             | 44.8                             |
| Working pressure bar                                      | 205              | 205                              | 225              | 225                                | 225                                | 185             | 185                 | 185                                | 185                                | 185              | 185                              |
| <b>DRIVE</b>  |                  |                                  |                  |                                    |                                    |                 |                     |                                    |                                    |                  |                                  |
| Type of drive   | Hydraulic        | Hydrostatic                      | Hydrostatic      | Hydrostatic                        | Hydrostatic                        | Hydrostatic     | Hydrostatic         | Hydrostatic                        | Hydrostatic                        | Hydrostatic      | Hydrostatic                      |
| Traction drive  | Oil motor        | Oil motor                        | Oil motor        | Drive shaft                        | Drive shaft                        | Oil motor       | Oil motor           | Drive shaft                        | Drive shaft                        | Drive shaft      | Drive shaft                      |
| <b>NOISE PARAMETERS</b>                                   |                  |                                  |                  |                                    |                                    |                 |                     |                                    |                                    |                  |                                  |
| Averaged acoustic power level LwA dB(A)                   | 99.7             | 99.7                             | 98.8             | 98.4                               | 98.4                               | 100.1           | 100.1               | 100.1                              | 100.1                              | 99.7             | 99.7                             |
| Guaranteed acoustic power level LwA dB(A)                 | 101              | 101                              | 101              | 101                                | 101                                | 101             | 101                 | 101                                | 101                                | 101              | 101                              |
| Specified acoustic pressure level LpA dB(A)               | 85               | 85                               | 85               | 84                                 | 84                                 | 84              | 85                  | 85                                 | 85                                 | 82               | 82                               |

All technical data in this brochure refer to series models that have been tested under operating conditions typical of Central Europe and describe their standard functions. Specifications and their modes of functionality as well as accessories listed in this brochure depend on the individual model and on the options available with a particular product as well as the statutory requirements of the country of sale. Illustrations used in this brochure may show products that have not been mentioned or that are not available as series production machines. The descriptions, illustrations, weights and technical data published herein are non-binding in nature and represent the technical status at the time the document went to press. Because of ongoing development, we reserve the right to make changes, without prior notice, to the design, specification, visual appearance and technology of our products. Should you require special functions that would be available only by using additional components and/or under special circumstances, please feel free to contact us. We will be happy to answer any questions you may have and to provide further information regarding whether and under what conditions applying to the product and the target environment such special functions might be feasible. If you have any concerns about the load capacity or operation of our products in certain working conditions or environments, we recommend that you perform a test run under controlled conditions. Despite meticulous attention to detail, we cannot exclude the possibility that our products may not conform to illustrations or stated dimensions, or that errors may have occurred in calculation or during printing, or that the information given here may be incomplete. Consequently, we do not accept liability for the accuracy or completeness of the information supplied in this brochure. All matters relating to our product warranty are contained within our General Terms and Conditions. We expressly decline to provide additional guarantees. Any liability over and above that contained within our General Terms and Conditions is excluded.

**Optional weights:**

- \* Ballast weight
- \*\* Cast rear weight
- \*\*\* Cast rear weight (base plate) and Cast rear weight

FSD = Overhead guard  
eps = Easy Protection System (foldable canopy)





**VIBRATIONS**

**LOADING TYPE**

**Compact wheel loader  
(operating weight < 4,500kg)**

**Wheel loader  
(Operating weight > 4,500 kg)**

| Typical operating conditions                   | Mean value            |                       |                     | Standard deviation (s) |                     |                     |
|--|-----------------------|-----------------------|---------------------|------------------------|---------------------|---------------------|
|  | $1.4 \cdot a_{w,eqx}$ | $1.4 \cdot a_{w,eqy}$ | $a_{w,eqz}$         | $1.4 \cdot s_x$        | $1.4 \cdot s_y$     | $s_z$               |
|  | [m/s <sup>2</sup> ]   | [m/s <sup>2</sup> ]   | [m/s <sup>2</sup> ] | [m/s <sup>2</sup> ]    | [m/s <sup>2</sup> ] | [m/s <sup>2</sup> ] |
| Load & carry (loading & transport work)        | 0.94                  | 0.86                  | 0.65                | 0.27                   | 0.29                | 0.13                |
| Load & carry (loading & transport work)        | 0.84                  | 0.81                  | 0.52                | 0.23                   | 0.20                | 0.14                |
| Use in production (rough operating conditions) | 1.27                  | 0.79                  | 0.81                | 0.47                   | 0.31                | 0.47                |
| Transporting                                   | 0.76                  | 0.91                  | 0.29                | 0.33                   | 0.35                | 0.17                |
| V operation                                    | 0.99                  | 0.84                  | 0.54                | 0.29                   | 0.32                | 0.14                |

**Whole-body vibrations:**

- Every machine is fitted with a driver's set that meets the requirements of EN ISO 7096:2000.
- When the loader is used correctly, the whole-body vibrations vary from less than 0.5 m/s<sup>2</sup> up to a brief maximum value.
- When calculating the vibrations in accordance with ISO/TR 25398:2006, it is recommended to use the values given in the table. When doing so, take into account the actual operating conditions.
- Like wheel loaders, telehandlers can be categorised according to operating weight.

**Hand-arm vibrations:**

- Hand-arm vibrations do not exceed 2.5 m/s<sup>2</sup>



# 1140 1160

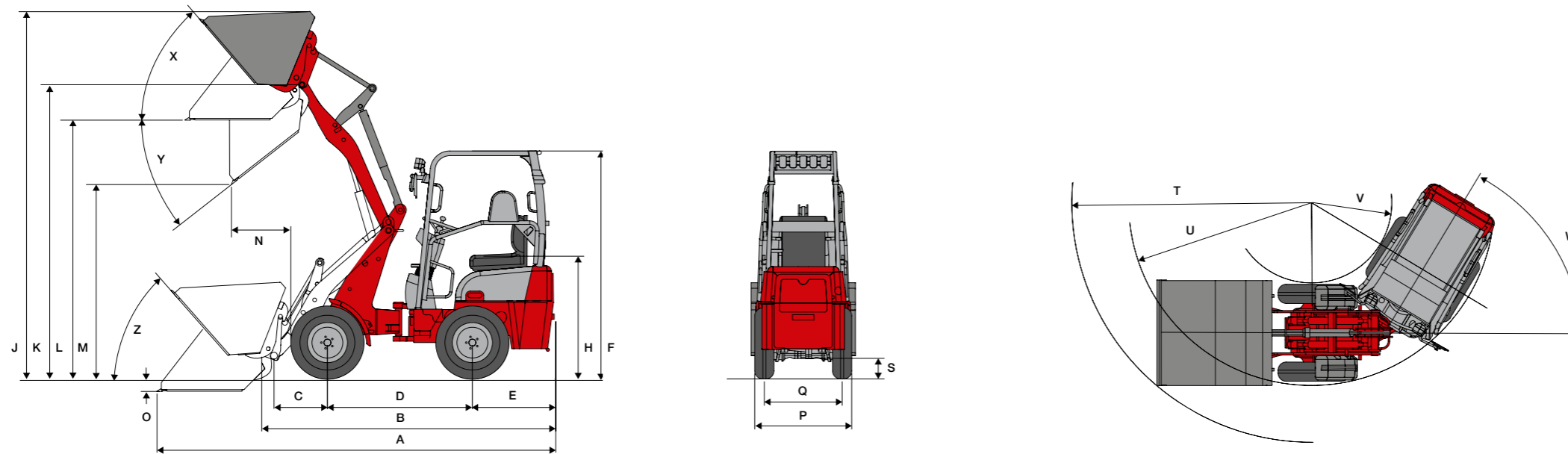

1140      1160

## DIMENSIONS

|   |   |       |               |
|---|---|-------|---------------|
| A | Total length mm                                     | 3,706 | 3,983 (4,182) |
| B | Total length without bucket mm                      | 2,733 | 3,005 (3,206) |
| C | Axle centre to bucket pivot point mm                | 496   | 508 (707)     |
| D | Wheel base mm                                       | 1,345 | 1,468         |
| E | Rear overhang mm                                    | 779   | 917           |
| F | Height to top of overhead guard fixed mm            | 2,124 | 2,237         |
|   | Height to top of overhead guard foldable mm         | 2,227 | 2,341         |
|   | Height to top of overhead guard foldable, folded mm | 1,937 | 1,928         |
| H | Seat height mm                                      | 1,142 | 1,273         |
| J | Total working height mm                             | 3,415 | 3,423 (3,634) |
| K | Max. height of bucket pivot mm                      | 2,734 | 2,740 (2,948) |
| L | Load-over height mm                                 | 2,405 | 2,421 (2,629) |
| M | Dumping height mm                                   | 1,807 | 1,799 (1,998) |
| N | Operating distance for M mm                         | 550   | 498 (433)     |
| E | Digging depth mm                                    | 113   | 97 (124)      |
| P | Total width mm                                      | 850   | 1,044         |
| Q | Track width mm                                      | 660   | 780           |
| S | Ground clearance mm                                 | 190   | 255           |
| T | Maximum radius external mm                          | 2,140 | 2,592 (2,706) |
| U | Radius at the outer edge mm                         | 1,570 | 2,138         |
| V | Inside turning radius mm                            | 600   | 1,017         |
| W | Inclination angle °                                 | 55    | 50            |
| X | Rollback angle at max. lifting height °             | 50    | 50 (47)       |
| Y | Max. dumping angle °                                | 39    | 40            |
| Z | Backroll angle on the ground* °                     | 48    | 49            |

1140

## WIDTHS / REVERSED mm

|                         |             |
|-------------------------|-------------|
| 7.00 - 12 AS ET65       | 800/1,060   |
| 7.00 - 12 AS ET40       | 850*/1,010* |
| 26 x 12 - 12 AS ET0     | 1,070       |
| 27 x 8.50 - 15 EM ET30  | 920/1,040   |
| 27 x 10.50 - 15 EM ET-5 | 1,000       |
| Twin tyres 7.00 - 12 AS | 1,390       |

1160

## WIDTHS / REVERSED mm

|                              |             |
|------------------------------|-------------|
| AXLE K80 / T80               |             |
| 10.0/75 - 15.3 AS ET10       | 1,044*      |
| 7.00 - 12 AS ET40            | 920/1,096   |
| 26 x 12 - 12 AS ET0          | 1,138       |
| 31 x 15.50 - 15 AS ET-50     | 1,270       |
| Twin tyres 7.00 - 12 AS      | 1,440       |
| 27 x 8.50 - 15 EM ET30       | 958/1,094   |
| 27 x 10.50 - 15 EM ET-5      | 1,076       |
| 26 x 12 - 12 RP ET0          | 1,138       |
| AXLE T94                     |             |
| 10.0/75 - 15.3 AS ET80       | 1,044/1,380 |
| 31 x 15.50 - 15 AS ET0       | 1,310       |
| Twin tyres 10.0/75 - 15.3 AS | 1,650       |
| 27 x 8.50 - 15 EM ET80       | 998/1,334   |
| 27 x 10.50 - 15 EM ET60      | 1,086       |
| 10.0 x 16.5 EM ET0           | 1,128/1,304 |
| 10.0/75 - 15.3 RP ET40       | 1,124       |



# 1260

# 1280

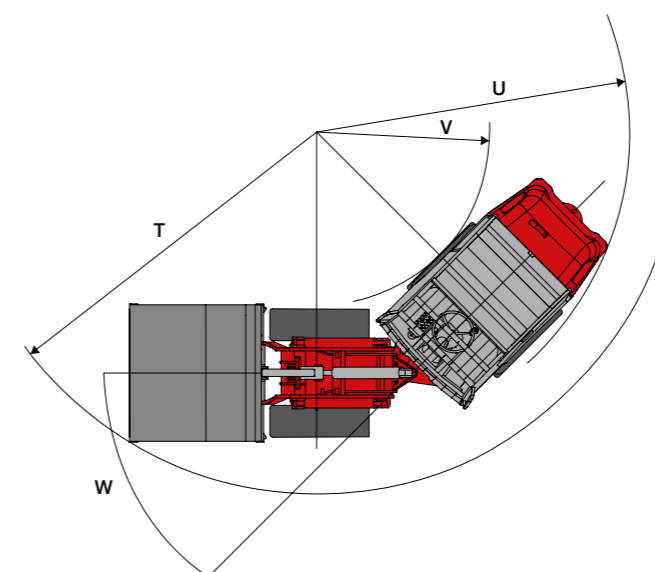
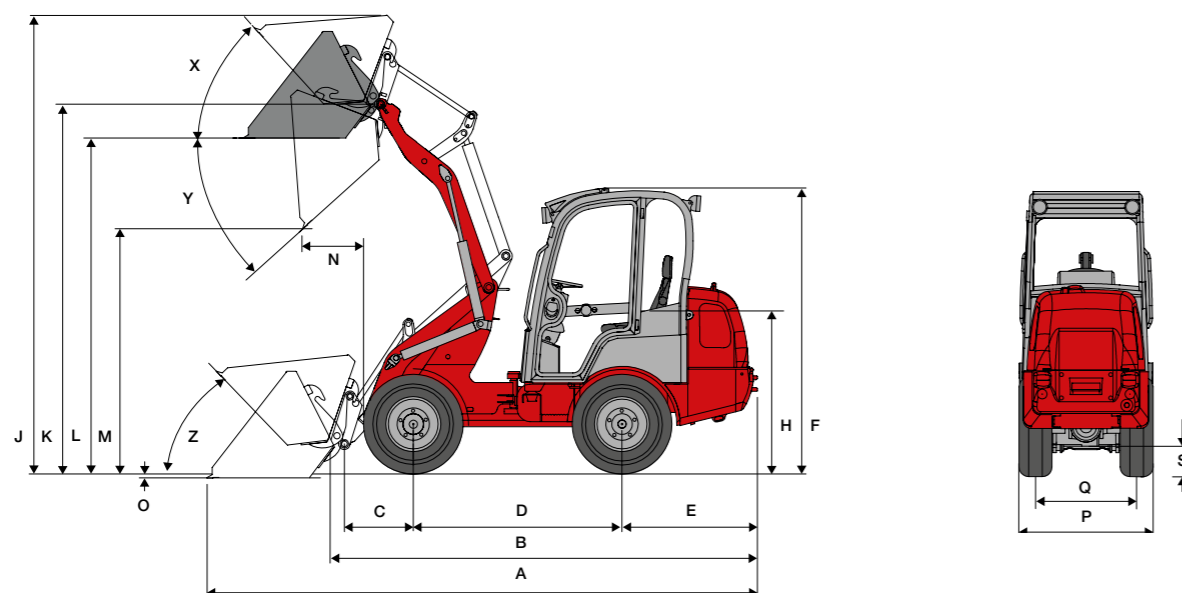

|  | 1240<br>CX35 LP | 1260<br>Standard | 1260<br>Ausstattungs-<br>beispiel 1 und 2 | 1280<br>Standard | 1280<br>Ausstattungs-<br>beispiel |
|--|-----------------|------------------|---|------------------|-----------------------------------|
|--|-----------------|------------------|---|------------------|-----------------------------------|

### DIMENSIONS

|          |  |               |               |               |       |               |
|----------|--|---------------|---------------|---------------|-------|---------------|
| <b>A</b> | <b>Total length</b> mm                                     | 4.103 (4.302) | 4.127 (4.351) | 4.127 (4.351) | 4.248 | 4.248 (4.471) |
| <b>B</b> | <b>Total length without bucket</b> mm                      | 3.115 (3.325) | 3.151 (3.374) | 3.151 (3.374) | 3.270 | 3.270 (3.495) |
| <b>C</b> | <b>Axle centre to bucket pivot point</b> mm                | 621 (780)     | 531 (757)     | 531 (757)     | 531   | 531 (757)     |
| <b>D</b> | <b>Wheel base</b> mm                                       | 1.544 (1.565) | 1.503         | 1.503         | 1.623 | 1.623         |
| <b>E</b> | <b>Rear overhang</b> mm                                    | 889           | 1.000         | 1.000         | 1.000 | 1.000         |
| <b>F</b> | <b>Height to top of overhead guard fixed</b> mm            | 1.900         | 2.156         | 2.229         | 2.184 | –             |
|          | <b>Height to top of overhead guard foldable</b> mm         | –             | 2.260         | 2.333         | 2.298 | –             |
|          | <b>Height to top of overhead guard foldable, folded</b> mm | –             | 1.846         | 1.919         | 1.780 | –             |
|          | <b>Height to top of cabin</b> mm                           | –             | –             | –             | –     | 2.208         |
| <b>H</b> | <b>Seat height</b> mm                                      | 961           | 1.190         | 1.265         | 1.259 | 1.259         |
| <b>J</b> | <b>Total working height</b> mm                             | 3.188 (3.607) | 3.473 (3.677) | 3.545 (3.749) | 3.545 | 3.545 (3.749) |
| <b>K</b> | <b>Max. height of bucket pivot</b> mm                      | 2.434 (2.922) | 2.788 (3.042) | 2.860 (3.114) | 2.860 | 2.860 (3.114) |
| <b>L</b> | <b>Load-over height</b> mm                                 | 2.135 (2.603) | 2.469 (2.723) | 2.541 (2.795) | 2.541 | 2.541 (2.795) |
| <b>M</b> | <b>Dumping height</b> mm                                   | 1.525 (1.972) | 1.812 (2.141) | 1.884 (2.213) | 1.884 | 1.884 (2.213) |
| <b>N</b> | <b>Operating distance for M</b> mm                         | 490 (533)     | 499 (547)     | 447 (495)     | 447   | 447 (495)     |
| <b>E</b> | <b>Digging depth</b> mm                                    | 55 (150)      | 153 (205)     | 81 (133)      | 81    | 81 (133)      |
| <b>P</b> | <b>Total width</b> mm                                      | 970           | 970           | 1.044         | 1.044 | 1.044         |
| <b>Q</b> | <b>Track width</b> mm                                      | 752           | 752           | 780           | 780   | 780           |
| <b>S</b> | <b>Ground clearance</b> mm                                 | 200           | 199           | 250           | 250   | 250           |
| <b>T</b> | <b>Maximum radius external</b> mm                          | 2.773         | 2.648 (2.776) | 2.712 (2.840) | 2.918 | 2.918 (3.037) |
| <b>U</b> | <b>Radius at the outer edge</b> mm                         | 2.311         | 2.203         | 2.197         | 2.541 | 2.541         |
| <b>V</b> | <b>Inside turning radius</b> mm                            | 1.270         | 1.083         | 1.046         | 1.423 | 1.423         |
| <b>W</b> | <b>Inclination angle</b> °                                 | 47            | 50            | 50            | 45    | 45            |
| <b>X</b> | <b>Rollback angle at max. lifting height</b> °             | 45 (46)       | 47 (52)       | 47 (52)       | 47    | 47 (52)       |
| <b>Y</b> | <b>Max. dumping angle</b> °                                | 42 (40)       | 43 (36)       | 43 (36)       | 43    | 43 (36)       |
| <b>Z</b> | <b>Backroll angle on the ground</b> °                      | 50 (49)       | 47 (48)       | 47 (48)       | 47    | 47 (48)       |

### WIDTHS / REVERSED mm

|                                 | 1240 CX LP    | 1260<br>Standard | 1260<br>Configuration<br>example 1 | 1260<br>Configuration<br>example 2 | 1280<br>Standard and<br>configuration<br>example |
|---------------------------------|---------------|------------------|------------------------------------|------------------------------------|--|
| <b>7.00 - 12 AS ET40</b>        | 900 / 1,060   | 900 / 1,060      | 920 / 1,100                        | –                                  | –  |
| <b>26 x 12 - 12 AS ET0</b>      | –             | 1,120            | 1,140                              | –                                  | –  |
| <b>10.0/75 - 15.3 AS ET10</b>   | –             | 1,040            | 1,044*                             | –                                  | –  |
| <b>10.0/75 - 15.3 AS ET80</b>   | –             | –                | –                                  | 1,044* / 1,380*                    | 1,044* / 1,380*                                  |
| <b>10.0/75 - 15.3 AS ET40</b>   | –             | –                | –                                  | 1,120 / 1,300                      | 1,120 / 1,300                                    |
| <b>10.0/75 - 15.3 AS ET-5</b>   | –             | –                | –                                  | 1,210                              | 1,210  |
| <b>31 x 15.50 - 15 AS ET0</b>   | –             | –                | –                                  | 1,340                              | 1,340  |
| <b>31 x 15.50 - 15 AS ET-37</b> | –             | –                | –                                  | 1,400                              | 1,400  |
| <b>31 x 15.50 - 15 AS ET-50</b> | –             | –                | 1,270                              | –                                  | –  |
| <b>27 x 8.50 - 15 EM ET30</b>   | 970* / 1,090* | 970* / 1,090*    | 958 / 1,094                        | –                                  | –  |
| <b>27 x 8.50 - 15 EM ET80</b>   | –             | –                | –                                  | 1000 / 1,340                       | 1,000 / 1,340                                    |
| <b>27 x 10.50 - 15 EM ET-5</b>  | 1,050         | 1,050            | 1,076                              | –                                  | –  |
| <b>27 x 10.50 - 15 EM ET60</b>  | –             | –                | –                                  | 1,090 / 1,350                      | 1,090 / 1,350                                    |
| <b>Twin tyres 7.00 - 12 AS</b>  | 1,260         | 1,260            | 1,320                              | –                                  | –  |



# At Weidemann, there's only one quality standard that counts in the end: Your complete satisfaction.

And at Weidemann, quality isn't just an empty shell of a word, it's a reality that's lived daily with true German attributes. That's because a genuine Weidemann comes from one of the most modern wheel loader and telehandler production plants. The new works that was opened in 2007 guarantees the consistently high quality of our products. And the result of this is safety, comfort and economy that you can always count on.

## Quality creates added value.

Another main feature of the special Weidemann quality claim is the powder coating. In contrast to ordinary wet painting, it significantly extends the machine's service life and at the same time is more efficient and gentle on the environment.

- 1 High-quality powder coating.
- 2-3 Sophisticated quality control of every machine.

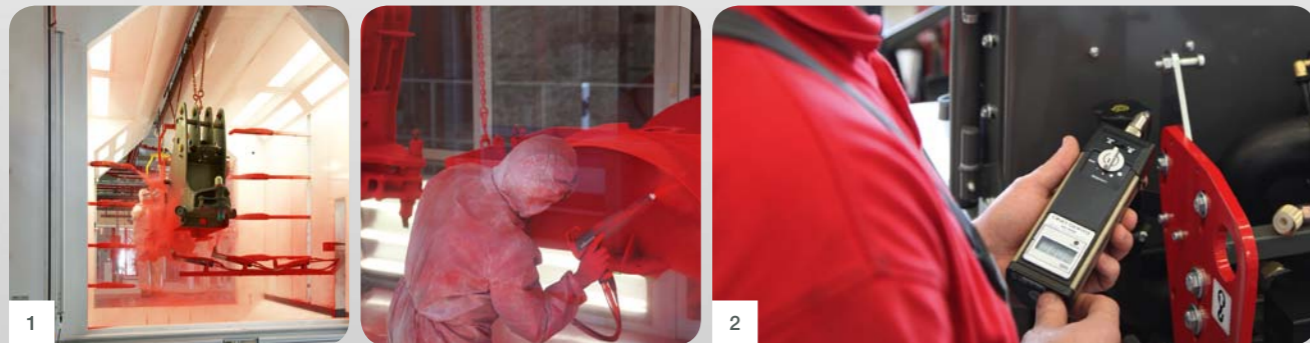

## QUALITY IS GOOD, FINAL INSPECTION IS BETTER.

Every Weidemann that leaves our plant has undergone a careful final inspection. Right from the outset, this guarantees our customers a long service life and reliability, great ease of operation and ease of repairs, along with low operating costs. That's because only where you see the name Weidemann on the outside will you also find Weidemann quality on the inside. And you can take that to the bank.



**GENUINE WEIDEMANN ORIGINALS ARE MADE PIECE BY PIECE AT THE STATE-OF-THE-ART PLANT IN KORBACH.**

A sophisticated production sequence and strict stock management ensure that all parts are in the right place at the right time. The completed Hoftracs®, wheel loaders and telehandlers are not allowed to leave the plant until after they have passed the final inspection.



**PRODUCTION LOCATIONS OF THE WACKER NEUSON GROUP**

- 1 Milwaukee, USA
- 2 Norton Shores, USA
- 3 Korbach, Germany
- 4 Pfullendorf, Germany
- 5 Reichertshofen, Germany
- 6 Linz, Austria
- 7 Kragujevac, Serbia
- 8 Manila, Philippines

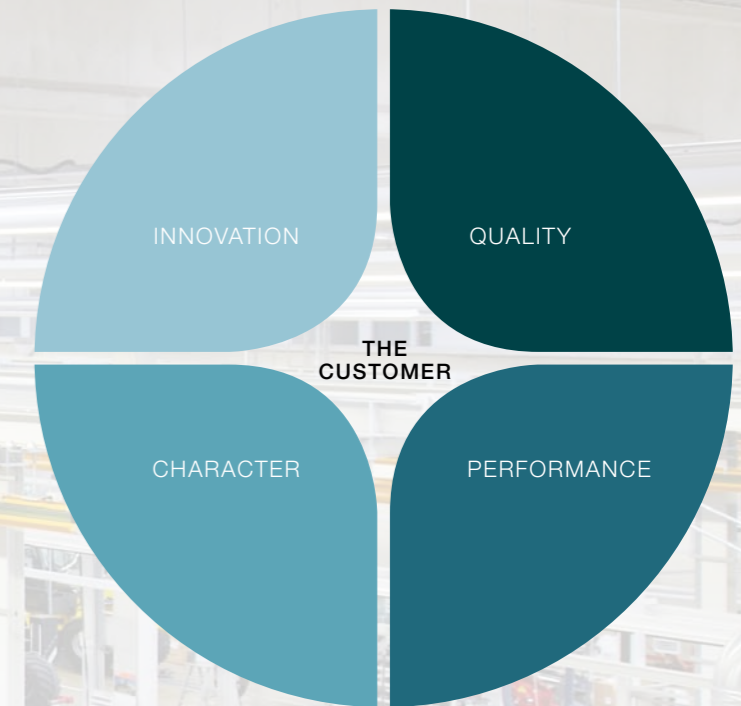

**The vision and values wheel:**  
The customer's success is the core of our philosophy.

We impress with the values of a medium-sized, stock market-listed family business. With the strength and competence of a global organisation. With people whose actions and ideas live up to our credo day in, day out.

Quality, innovation, performance and character are the things that we believe in. Along with the ongoing success of our customers around whom, after all, everything revolves.

