

TB295W

2-PIECE BOOM
Standard 10.4 TONNE

MONO BOOM
Standard 9.8 TONNE



STAGE V
READY



WHEELED EXCAVATOR

TAKEUCHI
From World First to World Leader

New TB295W wheeled excavator road ready & Stage V compliant

The latest Stage V ready TB295W is Takeuchi's new high-performance wheeled excavator, packed full of on-road features. A powerful 4 dual-wheel drive machine, the new TB295W is designed and built for motorway, road and streetworks applications with out-rigger options for added stability.

The TB295W is available as standard as a 2- piece boom with blade (mono boom optional). Now with twin boom rams for increased performance and greater versatility giving a maximum dump height of 6480mm and reducing the risk of ram damage when loading trucks.

With a massive dig depth of 4115mm and ground reach to 7555mm the TB295W provides heavy duty on-site performance and weighs in at 10,377 (10,667kg with outriggers).

A very flexible on-road vehicle built for maximum excavator performance.

Complete with a 85kW Deutz turbo engine;

Stage V • Low Emission • Low Noise.

Power performance combined with maximum breakout force all compliant with low emission zone regulations.

STAGE V ✓
READY



HEAVY DUTY BUILD - POWERFUL

Powered by a very fuel-efficient Stage V turbo Deutz Engine, combined with AdBlue.

The turbocharged diesel engine with auto idle and a dial throttle control provide fuel saving economy.

The heavy-duty boom and dipper arms are robust for tough breaking out.





OPERATOR COMFORT

A large enclosed ROPS/FOPS cab with digital air-con climate control as standard, along with retractable front window, wiper, rainguard and sunshade.

The automotive styled interior features intuitive controls, ample space, improved comfort and visibility.

The 10-way adjustable high back heated air suspension seat provides for the operator's optimal position for all day driving and excavating. AM/FM Bluetooth radio, USB socket and 12V + 24V power outlet.



NEW LED LIGHTING

Improved visibility in the dullest winter conditions with powerful workzone LED lighting.



Takeuchi's TB295W is a proven powerful wheeled excavator ideal for streetworks / on-road excavating. For plant hire and groundworks contractors, a wheeled option is essential for road applications and the new TB295W offers a powerful addition to the fleet. The two-piece boom arrangement offers versatility to reduce working height, ideal in confined working zones.

Retracting the boom (moving the load centre closer to the excavator) enhances lift performance, out-lifting a mono boom when up close to the machine. The working range with a two-piece boom is superior to that of the mono boom, allowing the operator to navigate around site utilities far easier. Operators get greater versatility when operating attachments.

With a reputation for reliability, Japanese build quality makes all the difference.



ROAD FEATURES

TB295W is a road legal vehicle when registered and taxed.

A highly flexible on-road excavator, with heavy duty twin wheels, industrial 14 ply tyres, rugged axles and undercarriage provide heavy duty strength in all terrains.

DRIVING

The TB295W is an easy to drive wheeled option with all the typical-on-road features, an adjustable steering column both height and rake, provides for all sizes of operators to give a comfortable drive.

Selectable hand or foot engine speed controls and fully supported travel pedal, footrests and offset foot pedal.

TRAVEL SPEED

With up to 30kph travel speed and auto cruise facility, the TB295W is ideal for on-road highways and street works applications.

SAFETY

Hi visibility well positioned road and LED workzone lights alongside reversing mirrors make for the safest possible drive. The added height of TB295W gives excellent all-round operator visibility on-road and on-site with in-built reversing camera as standard. Heavy duty anti-slip steps and prop-shaft guard for added on-site protection.

BRAKES

Highly efficient oil immersed hydraulic brakes with locking foot brake pedal, switch activated parking brake and selectable switch from manual to auto axle lock when digging.

AXLE & UNDERCARRIAGE

The undercarriage and axles are built for the rigours of road and site with rigid strength and switch activate diff lock for added traction. The undercarriage has universal out rigger and blade mounting points at both ends of the machine and onboard anti-roll wheel chocs.



NEW LCD FULL COLOUR DISPLAY

Provides easy to see functionality. The colour VDU gives excellent operator control illuminating all machine functions and warning alerts. The split screen displays both the operating functions and the wide angle, colour rear-view camera, with auto reverse activation.

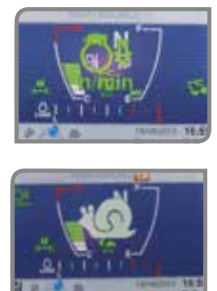

TFM - TAKEUCHI FLEET MANAGEMENT

Takeuchi Fleet Management is designed to help you better manage your fleet and lower your overall operating costs.



PROTECT YOUR INVESTMENT

The TB295W comes with the **TSS Takeuchi Security System** as standard.



MAXIMUM OPERATING PERFORMANCE



With a machine footprint of just 2335 x 3745mm, the new TB295W has a relatively compact size to get maximum accessibility on restricted streetwork sites.

Takeuchi joystick controls and conveniently located switch arrangement give finger-tip precision control with smooth hydraulics. Fitted with cushioned main boom, arm and swing cylinders. a hose-burst check valve, to maintain load control in the event of a hose failure. Adjustable auxiliary flow and password protected settings with multiple attachment presets all accessible from operator seat.

The selectable lift alarm provides an audible warning when the boom is reaching maximum hydraulic lifting capacity.

MAINTENANCE FEATURES



The TB295W is designed for maximum service access right round the cab.

The new Stage V engine now comes with DPF and SCR emission after-treatment

Ground level easy access points for the battery and regular service points.



The machine comes with a large well positioned toolbox under the cab, supplied with a tool kit and grease gun.

Electric refuelling pump with extended length for easy fuelling.

Reliable well protected hydraulic hoses help reduce maintenance costs.



- Electronic engine monitoring system
- Self bleeding fuel system - high capacity fuel filters
- TFM - remote engine monitoring system
- New radiator coolant sight gauge
- Service interval - 500 hours



ON - SITE FEATURES



Wide-angle colour rear-view camera, with auto-reverse activation.

The rear fisheye mirror, LED workzone lighting and roof beacon socket all provide maximum on-site safety.

A larger than average parallel lift dozer blade as standard provides for effective grading and ground clearance.

INDEPENDENT OUT RIGGERS are a factory fitted option. Easy to position to provide the added stability that might be required on gradients and un-even terrain.



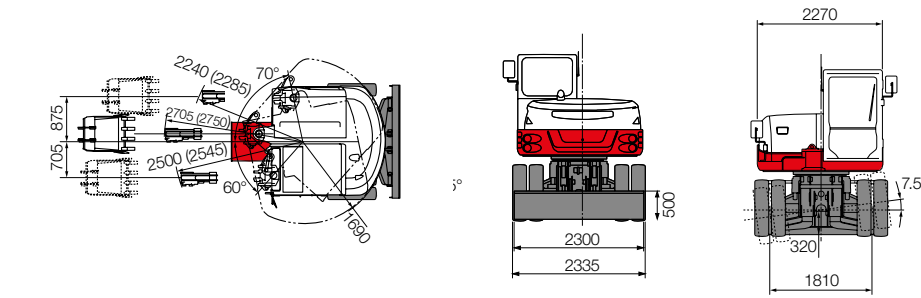

Mono Boom (optional)

2-piece Boom (standard)

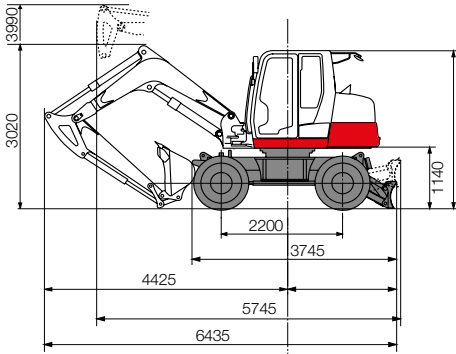

Mono Boom (optional)

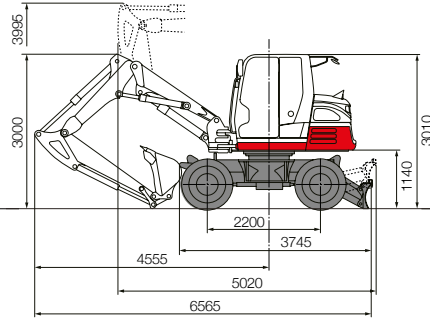

2-piece Boom (standard)

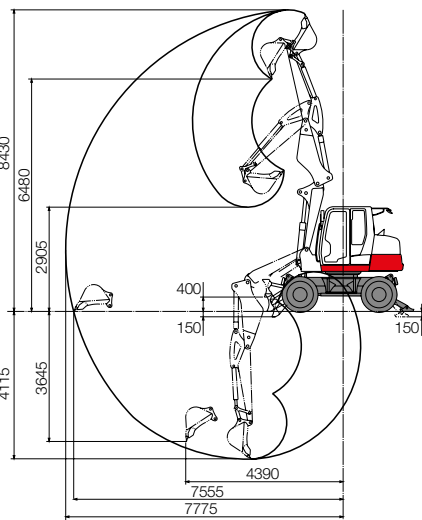
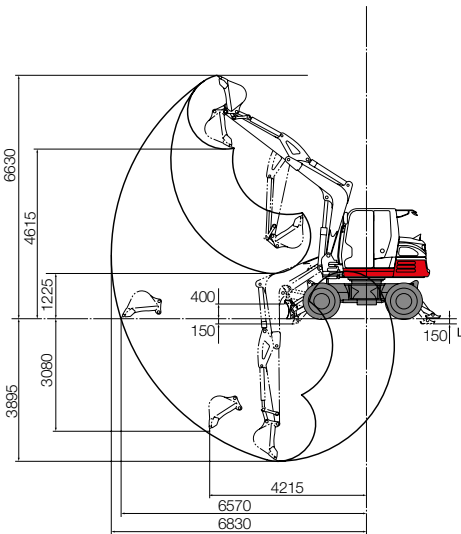

TB295W Stage V Standard UK Specification Long Dipper – 2-piece Boom (Mono Boom is an option)

Engine	
Make	DEUTZ
Model	TCD3 6L4
Rated Output (kW)/rpm/HP	85 / 2200 / 113.9
Cylinders	4
Displacement (cc)	3621
Electrical System	24V 90A x2
Dimensions & Weight	
Operating Weight 2 Piece Boom (bucket, hitch, fuel, blade/with outrigger)	10377 / 10667kg
Operating Weight Mono Boom (bucket, hitch, fuel, blade/with outrigger)	9815 / 10105kg
Overall Length (mm)	6565 (6435)
Overall Length on road (mm)	5020 (5745)
Width (mm)	2335
Height (mm)	3010
Ground Clearance (mm)	320
Operating Information	
Max Digging Depth (mm)	4115 (3895)
Max Dump Height (mm)	6480 (4615)
Max Reach at Ground Level (mm)	7555 (6570)
Max Vertical Digging Depth (mm)	3645 (3080)
Bucket Digging Force (kN)	58.9
Long Arm Digging Force (kN)	39.7
2-piece boom Max Lift Full Reach daN* (front/ side /rear)	1372 / 723 / 1013
2-piece boom Max Lift daN* (front / side / rear)	3773 / 2540 / 3390
Hydraulic System	
Set Pressure (bar)	275
Pump Type	Variable piston x 2, double gear x 1
1st Auxiliary Maximum Flow (l/min) / Pressure (bar)	120 / 200
*2nd Auxiliary Maximum Flow (l/min) / Pressure (bar)	46 / 200
Swing System	
Boom Swing Angle (R/L)	60° / 70°
Slew Speed (rpm)	10.1
Slew Motor	Constant Vol Piston
Slew Brake	Disc
Undercarriage	
Tyre Size	8.25 - 20 - 14PR
Drive Line	All Wheel Drive
Travel Brake	Disc & Brake Lock
Steering	Front Setting System
Wheelbase	2200
Tyre Pressure (psi)	95
Travel Speed - 2 speeds (km/h)	0-5.3 - 15.4 / 0-10.3 - 29.7
Maximum Gradeability	35°
Capacities	
Hydraulic System (l)	200
Fuel Tank (l)	162
AdBLUE (l)	10
Engine Lubrication (l)	10

**2 YEAR
2,000 HOUR**

WARRANTY*

Takeuchi machines come with a 2 year/2000 hours warranty as standard. Warranty exceptions to 1 year: fuel injection systems, electrical components, paint work and *emission control items. (*applicable models).

Before fitment of a hydraulic attachment, machine auxiliary pressure and flow should be accurately measured.

*Lifting; the mass weight of slings / hitches / bucket to be deducted from the rated load to determine the net load that may be lifted.

In accordance with our established policy of constant improvement, we reserve the right to amend these specifications at any time without notice. Photographs shown may feature non-standard equipment.

5/2021

For more information locally contact:

Takeuchi Mfg (UK) Ltd, Unit E2B Kingsway Business Park,
John Boyd Dunlop Drive, Rochdale, Lancashire OL16 4NG
Tel: 01706 657 722 Email: info@takeuchi-mfg.co.uk
www.takeuchi-mfg.co.uk



TAKEUCHI
From World First to World Leader